

New!

Advanced Breading Technology

RP (Round Product) Accessory for Automatic Coating Systems

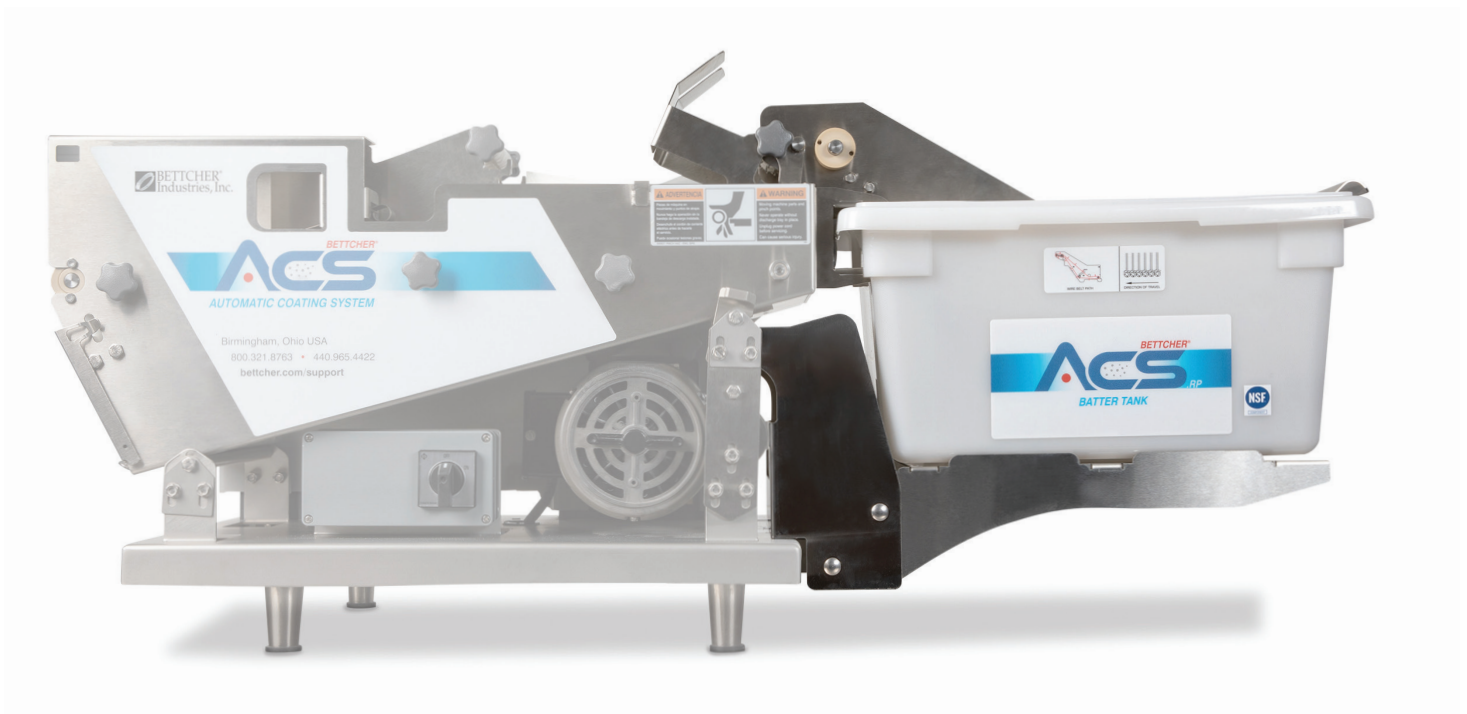

Product Description

The RP accessory for the Automatic Coating System from Bettcher enables foodservice workers to load scoops of product into the

batter tank for fast, efficient coating. There's no need to drop in each food product individually. This saves on prep time and improves kitchen workplace efficiencies.

The RP accessory easily accommodates any-sized round-profile food product up to 3" in diameter.

Easy to Use ... Easy to Clean

The RP accessory is designed for ease of use. It removes and reattaches easily for product changes and cleaning. The RP is fully submersible and is sized for commercial dishwashers or hand-washing in three-compartment or power-wash sinks.

Accessorize Easily

The RP accessory is available on all new ACS Automatic Coating System. It can also be easily retrofitted to existing ACS and ABB Automatic Batter Breeder machines.



RP (Round Product) Accessory

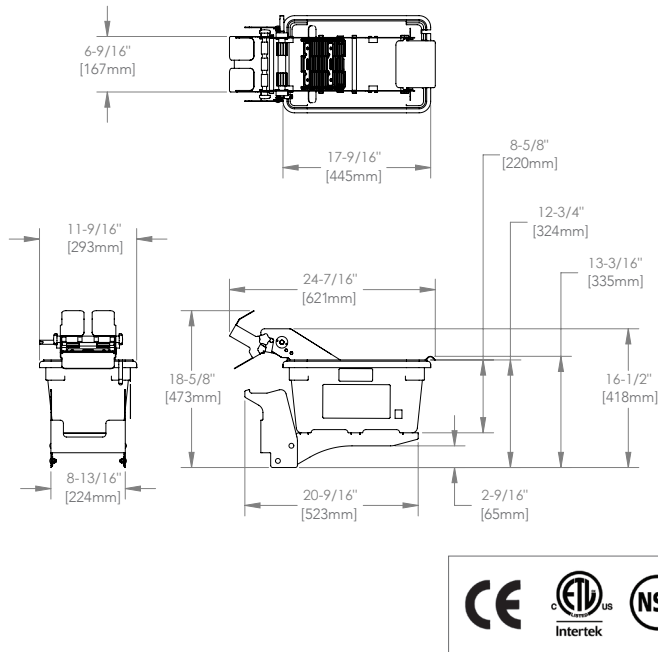

Automatic Coating System – Complete Machine

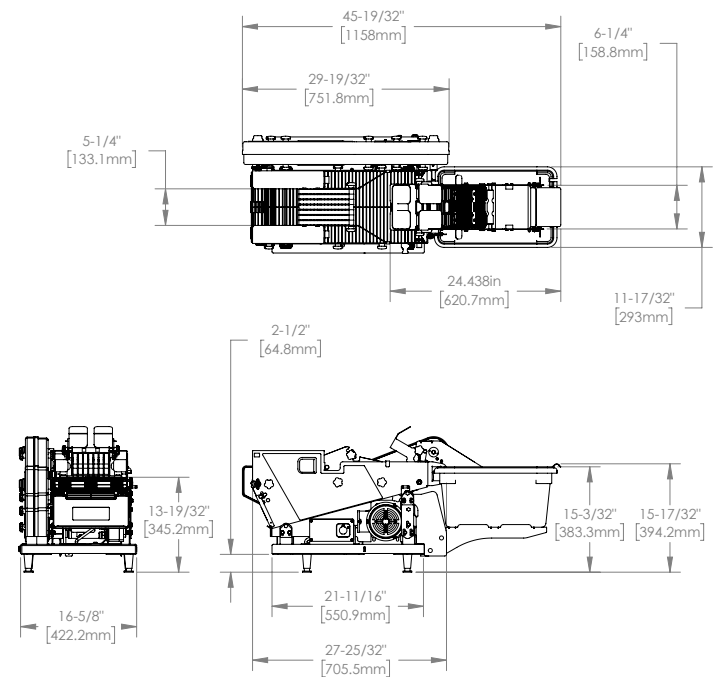

Product Specifications

RP (Round Product) Accessory

Model

107304

Weight

Total Machine: 16 lbs. (7.25 kg)

Batter Conveyor: 8 lbs. (3.62 kg)

Batter Tank: 3 lbs. (1.36 kg)

Batter Tank Bracket: 6 lbs. (2.72 kg)

Speeds

Batter Conveyor: 20 ft./min. (6.1 m/min)

Usable Belt Width: 6 in. (152 mm)

Capacity

Batter Capacity: 12 qt. (11.35 l)



Automatic Coating System – Complete Machine

Models

107304: RP (Accessory only)

107423: ACS.RP Complete Machine 115V

107424: ACS.RP Complete Machine 115V, Canada

107425: ACS.RP Complete Machine 230V, English

Weight

Total Machine: 120 lbs. (55 kg)

Frame: 67 lbs. (31 kg)

Breeder Conveyor: 36 lbs. (16 kg)

Batter Conveyor: 8 lbs. (3.62 kg)

Batter Tank: 3 lbs. (1.36 kg)

Batter Tank Bracket: 6 lbs. (2.72 kg)

Speeds

Batter Conveyor: 20 ft./min. (6.1 m/min)

Breeding Conveyor: 34 1/2 ft./min. (10.5 m/min)

Usable Belt Width: 6 in. (152 mm)

Power Requirements

Power Source 115 VAC/ 1 Phase/ 60 Hz ... 2.4 A ... 186 watts

Power Source 230 VAC/ 1 Phase/ 50 Hz ... 1.39 A ... 142 watts

Capacity

Batter Capacity: 12 qt. (11.35 l)

Breeding Capacity: 6-18 lbs. (3.7 to 8.1 kg)