

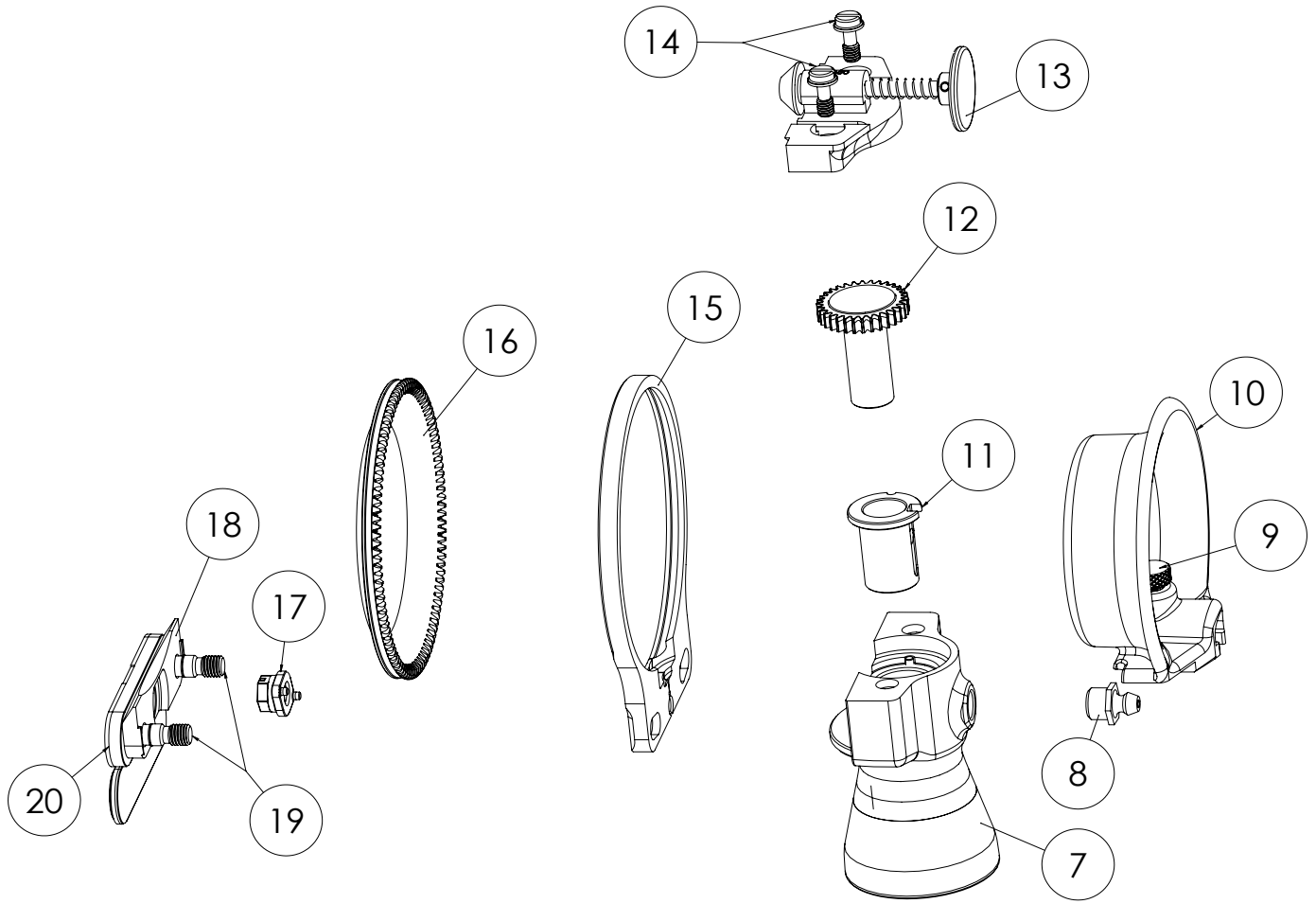

FOR USE WITH THE WHIZARD VERSA™ UNIT

Operating Instructions and Parts List for the Bettcher® Whizard Versa™

MANUAL #130555, ISSUED: AUGUST 1, 2024



Item No.	Description
1	Power Cable
2	Speed Button
3	Safety Latch
4	Lever
5	Motor Assembly
6	Driver Tip
7	Frame
8	Grease Fitting
9	Knob
10	Depth Gauge (<i>optional</i>)
11	Bearing
12	Pinion
13	Cover Assembly
14	Screw
15	Blade Housing
16	Blade
17	Cam
18	Cam Plate Assembly
19	Screw
20	Blade Replacement Cap and Cover (NSF)

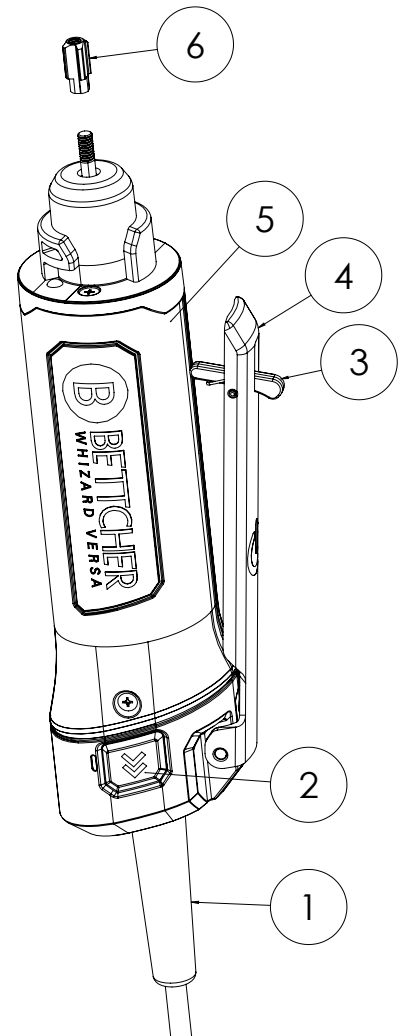

Parts and part numbers will vary based on tool purchased.
 For a full list of part numbers, *refer to page 36.*

MANUAL #130555

Issued: AUGUST 1, 2024

For Assistance:

E-mail:

sales@bettcher.com

Address:

BETTCHER INDUSTRIES INC.
6801 State Route 60
Birmingham, OH
44889 U.S.A.

Phone:

440/965-4422
800/321-8763

Fax:

440/328-4535

www.bettcher.com/whizard-versa

Information in this document is subject to change without notice.

No part of this document may be reproduced or transmitted in any form or any means, electronic or mechanical, for any purpose, without the express written permission of Bettcher Industries Inc.

Written permission to reproduce in whole or part is herewith granted to the legal owners of the Whizard Versa™ System with which these Operating Instructions have been supplied.

Operating Instructions in other languages are available on request. Additional copies of Operating Instructions are available by calling or writing your Regional Manager, or by contacting:

Address:

BETTCHER INDUSTRIES INC.
6801 State Route 60
Birmingham, OH
44889 U.S.A.

Phone:

440/965-4422
800/321-8763

Fax:

440/328-4535

www.bettcher.com/whizard-versa

WARNING: Read all safety warnings, instructions, illustrations and specifications provided with this power tool. Failure to follow all instructions listed below may result in electric shock, fire and/or serious injury.



MACHINE SPECIFICATIONS

The Bettcher® Whizard Versa™ is in conformity with the following directives:

2014/35/EU	Low Voltage Directive
2014/30/EU	Electromagnetic Compatibility Directive

This includes conformity with the following standards:

UL 62841-1	Electric Motor-Operated Hand-Held Tools, Transportable Tools And Lawn And Garden Machinery - Safety
CSA C22.2#62841-1:2015	Electric Motor-Operated Hand-Held Tools, Transportable Tools and Lawn and Garden Machinery - Safety
IEC 62841-1:2014	Electric Motor-Operated Hand-Held Tools, Transportable Tools and Lawn and Garden Machinery - Safety
CISPR 14-1: 2020	EMC - Requirements for household appliances, electric tools and similar apparatus - Emissions
BS EN 55014-1:2017/A11:2020	EMC - Requirements for household appliances, electric tools and similar apparatus - Emissions
CISPR 14-2: 2020	EMC - Requirements for household appliances, electric tools and similar apparatus - Immunity
BS EN 55014-2:1997/A2:2008	EMC - Requirements for household appliances, electric tools and similar apparatus - Immunity
IEC 61000-3-2:2018/AMD1:2020	EMC - Limits for harmonic current emissions
BS EN 61000-3-2:2019/A1:2021	EMC - Limits for harmonic current emissions
IEC 61000-3-3:2013/AMD2:2021/COR1:2022	EMC - Limitation of voltage changes, voltage fluctuations and flicker
EN 61000-3-3:2013/A2:2021/AC:2022	EMC - Limitation of voltage changes, voltage fluctuations and flicker
AS/NZS CISPR 14.1	EMC - Requirements for household appliances, electric tools and similar apparatus - Emission
IEC/EN 62233 Edition 1.0: 2005-10	EMC - Testing and Measurement - Human exposure
NSF/ANSI 8:2023	Commercial Powered Food Preparation Equipment (NSF/ANSI 8:2023 is only applicable for the stainless steel Gyro and Shawarma tools: 130885 and 130188)

To comply with the NSF certification, users must ensure the Gyro and Shawarma Gauges are installed and in good working order, free from damage. In addition, the blade replacement cap and cover must also be installed on the tool and in good working order, free from damage. Using the tool without these components voids the NSF certification.

NOTICE

This Declaration of Conformity applies only to the original equipment and to original equipment replacement parts as sold by Bettcher Industries or its authorized distributors. The use of replacement parts or equipment that are not manufactured or sold by Bettcher Industries, Inc. or its authorized distributors may cause or contribute to non-compliance of the specified Products to this Declaration of Conformity, the consequences of which is then the sole responsibility of the owner of these products.

TABLE OF CONTENTS

SAFETY

Section 1

Signal word panels	12
Safety symbols	13
Safety recommendations and warnings	14
General power tool safety warnings	15

TOOL SPECIFICATIONS

Section 2

Features and specifications	20
Ergonomic features	20
Noise and vibration levels	20
Tool speed	20
Electrical specifications	21
Recommended operating conditions	21

OPERATING INSTRUCTIONS

Section 3

Operating instructions	24
Attaching/detaching a Whizard Versa™ head to a Whizard Versa™ handle	24
Attaching Whizard Versa™ to power supply	24
Whizard Versa™ speed control	24
Operating the Whizard Versa™	25
Accessories	25

TABLE OF CONTENTS (CONTINUED)

MAINTENANCE

Section 4

Disassembly of handpiece	28
Assembly of handpiece	29
Daily inspections and maintenance	30
Cleaning	31
Blade sharpening	32
Steeling the blade	33
Troubleshooting	34

SERVICE PARTS

Section 5

Whizard Versa™ - part numbers	36
Also available	39

CONTACT AND DOCUMENT INFORMATION

Section 6

Contact address and phone	42
Document identification	43

SECTION 1

Safety

Signal word panels	12
Safety symbols	13
Safety recommendations and warnings	14
General power tool safety warnings	15

The information provided in these operating instructions is important to your health, comfort and safety. For safe and proper operation, read this entire manual before using this equipment.



Please read and save these instructions. Read carefully before attempting to assemble, install, operate or maintain this product. Protect yourself, others and equipment by observing all safety information.



Failure to comply with instructions could result in personal injury and/or damage to the equipment. Any use in applications other than those for which the equipment was designed and built may result in equipment damage and/or serious injuries.

Retain this manual for future reference. Be thoroughly familiar with the controls and proper use of this equipment.

The manufacturer assumes no liability for any unauthorized changes in operating procedures or for unauthorized changes or modifications made to the design of the machine or any factory-installed safety equipment, whether these changes are made by the owner of this equipment, by his employees, or by service providers not previously approved by Bettcher Industries, Inc.

SIGNAL WORDS AND SIGNAL WORD PANELS

Indicates a hazardous situation that, if not avoided, will result in death or serious injury.

(The signal word DANGER is in white letters on a safety red background)



Indicates a hazardous situation that, if not avoided, could result in death or serious injury.

(The signal word WARNING is in black letters on a safety orange background)



Indicates a hazardous situation that, if not avoided, could result in minor or moderate injury.

(The signal word CAUTION is in black letters on a safety yellow background)



Indicates information considered important but not hazard-related (e.g. messages relating to property damage).

(The signal word NOTICE is in italicized, white letters on a safety blue background)



The signal word definitions provided, comply with the American National Standard for Product Safety Information in Product Manuals, Instructions, and Other Collateral Materials (ANSI Z535.6-2011).

This technical manual is printed in black and white.

SAFETY SYMBOLS

The safety alert symbol indicates a potential personal injury hazard.

It is not used for messages related to property damage.

The safety alert symbol may be used alone or in conjunction with a signal word in a signal word panel.



Danger of electrical shock.



Blade hazard, keep hands clear.



Read operator's manual.



Protective safety gloves must be worn.



Symbols are harmonized with ANSI Z535.4 and ISO 3864-2 standards. Warning symbols are presented on a safety yellow background. Mandatory action symbols are presented on a safety blue background.

This technical manual is printed in black and white.

SAFETY RECOMMENDATIONS AND WARNINGS

The manufacturer assumes no liability for any unauthorized changes in operating procedures or for unauthorized changes or modifications made to the design of the machine or any factory-installed safety equipment, whether these changes are made by the owner of this equipment, by his employees, or by service providers not previously approved by Bettcher Industries, Inc.



Use only replacement parts manufactured by Bettcher Industries, Inc. Use of substitute parts will void the warranty and may cause injury to operators and damage to equipment.

The use of parts other than those listed in the parts list for the specific model may cause blade lock-up, resulting in an unsafe operating conditions.

Sharp blade may cause cut injury!



For proper protection of hands, a protective glove should be used when operating this equipment and during the handling of blades. Metal mesh gloves are recommended for the free hand.



Keep hands away from moving blade.

ALWAYS disconnect the tool from power supply prior to performing any adjustments, disassembly/assembly, troubleshooting or cleaning.



If at any time this machine does not appear to operate normally or exhibits a marked change in performance, it should be immediately shut down, unplugged, and tagged as "UNSAFE" until such time as proper repairs are made and the machine again operates normally.



Avoid use of this machine in standing water.

Long or repeated use of various power tools vibrating excessively is suspected of contributing to certain hand, wrist or forearm disorders in susceptible individuals.



Prolonged usage may cause the handpiece to become hot and cause burns from sustained usage. Proper PPE required during usage including an insulated glove.



If excessive vibration occurs, it is an indication that there are worn parts that need replacement.



If your unit develops unusual vibration, do not continue to use it without first undertaking corrective action as outlined in the troubleshooting guide in this operating instruction.



DO NOT use aggressive detergents.

Avoid the use of aggressive cleaning products as they will damage the aluminum frames assembly.



GENERAL POWER TOOL SAFETY WARNINGS

WORK AREA SAFETY

- Keep work area clean and well lit. Cluttered or dark areas invite accidents.
- Do not operate power tools in explosive atmospheres, such as in the presence of flammable liquids, gases or dust. Power tools create sparks which may ignite the dust or fumes.
- Keep children and bystanders away while operating a power tool. Distractions can cause you to lose control.

ELECTRICAL SAFETY

- Power tool plugs must match the outlet. Never modify the plug in any way. Do not use any adapter plugs with earthed (grounded) power tools. Unmodified plugs and matching outlets will reduce risk of electric shock.
- Avoid body contact with earthed or grounded surfaces, such as pipes, radiators, ranges and refrigerators. There is an increased risk of electric shock if your body is earthed or grounded.
- Do not expose power tools to rain or wet conditions. Water entering a power tool will increase the risk of electric shock.
- Do not abuse the cord. Never use the cord for carrying, pulling or unplugging the power tool. Keep cord away from heat, oil, sharp edges or moving parts. Damaged or entangled cords increase the risk of electric shock.
- When operating a power tool outdoors, use an extension cord suitable for outdoor use. Use of a cord suitable for outdoor use reduces the risk of electric shock.
- If operating a power tool in a damp location is unavoidable, use a Residual Current Device (RCD) protected supply. Use of an RCD reduces the risk of electric shock.

GENERAL POWER TOOL SAFETY WARNINGS (CONTINUED)

PERSONAL SAFETY

- Stay alert, watch what you are doing and use common sense when operating a power tool. Do not use a power tool while you are tired or under the influence of drugs, alcohol or medication. A moment of inattention while operating power tools may result in serious personal injury.
- Use personal protective equipment. Always wear eye protection. Protective equipment such as dust mask, non-skid safety shoes, hard hat, or hearing protection used for appropriate conditions will reduce personal injuries.
- Prevent unintentional starting. Ensure the switch is in the off-position before connecting to power source and/or battery pack, picking up or carrying the tool. Carrying power tools with your finger on the switch or energizing power tools that have the switch on invites accidents.
- Remove any adjusting key or wrench before turning the power tool on. A wrench or a key left attached to a rotating part of the power tool may result in personal injury.
- Do not overreach. Keep proper footing and balance at all times. This enables better control of the power tool in unexpected situations.
- Dress properly. Do not wear loose clothing or jewelry. Keep your hair, clothing and gloves away from moving parts. Loose clothes, jewelry or long hair can be caught in moving parts.
- If devices are provided for the connection of dust extraction and collection facilities, ensure these are connected and properly used. Use of dust collection can reduce dust-related hazards.
- Do not let familiarity gained from frequent use of tools allow you to become complacent and ignore tool safety principles. A careless action can cause severe injury within a fraction of a second.

GENERAL POWER TOOL SAFETY WARNINGS (CONTINUED)

POWER TOOL USE AND CARE

- Do not force the power tool. Use the correct power tool for your application. The correct power tool will do the job better and safer at the rate for which it was designed.
- Do not use the power tool if the switch does not turn it on and off. Any power tool that cannot be controlled with the switch is dangerous and must be repaired.
- Disconnect the plug from the power source and/or remove the battery pack, if detachable, from the power tool before making any adjustments, changing accessories, or storing power tools. Such preventive safety measures reduce the risk of starting the power tool accidentally.
- Store idle power tools out of the reach of children and do not allow persons unfamiliar with the power tool or these instructions to operate the power tool. Power tools are dangerous in the hands of untrained users.
- Maintain power tools and accessories. Check for misalignment or binding of moving parts, breakage of parts and any other condition that may affect the power tool's operation. If damaged, have the power tool repaired before use. Many accidents are caused by poorly maintained power tools.
- Keep cutting tools sharp and clean. Properly maintained cutting tools with sharp cutting edges are less likely to bind and are easier to control.
- Use the power tool, accessories and tool bits etc. in accordance with these instructions, taking into account the working conditions and the work to be performed. Use of the power tool for operations different from those intended could result in a hazardous situation.
- Keep handles and grasping surfaces dry, clean and free from oil and grease. Slippery handles and grasping surfaces do not allow for safe handling and control of the tool in unexpected situations.

SERVICE

- Have your power tool serviced by a qualified repair person using only identical replacement parts. This will ensure that the safety of the power tool is maintained.

SECTION 2

Tool Specifications

Features and specifications	20
Ergonomic features	20
Noise and vibration levels	20
Tool speed	20
Electrical specifications	21
Recommended operating conditions	21

FEATURES AND SPECIFICATIONS

The Whizard Versa™ is designed to be used with either a universal AC power supply or a 36V battery. The lever has been designed in such a way that minimal grip force is required for operation, using three fingers. The lever also has a safety latch to prevent accidental activation of the tool. The Whizard Versa™ also has a safety cut off if the tool sees too high of a load, cycling the tool on and off will correct this. The tool will also shut down if it comes close to overheating. Allow the tool to cool down and it will be ready to be used.

ERGONOMIC FEATURES

The Whizard Versa™ head can be placed in two positions 180° apart to let the operator have the lever either in the palm of their hand or held down by their fingers.

The Whizard Versa™ has two different power supply options, either a universal AC power supply or a 36V battery that allows for a greater range of motion.

NOISE AND VIBRATION LEVELS

- The noise emission value is 83.7 dB(A) on maximum speed at operator ear position measured per ISO 11201.
- Vibration of the handpiece is less than 2.5 m/sec².
- No negative side effects have been reported.

TOOL SPEED

- Low speed - 3500 rpm.
- High speed - 6000 rpm.

ELECTRICAL SPECIFICATIONS

- Tool: 27V $\overline{\text{---}}$ 2A.
- Power Supply Input: 100-240V~ 50-60Hz $\overline{\text{---}}$ 4.0A.
- Power Supply Output: 30V $\overline{\text{---}}$ 10A.

RECOMMENDED OPERATING CONDITIONS

- Recommended operating temperature: -5°C to 30°C (23°F to 86°F).
- Recommended storage temperature: -25°C to 55°C (-13°F to 131°F).
- Recommended operating humidity: 10% to 90%.
- Recommended operating barometric pressure: 850mb to 1100mb.

SECTION 3

Operating Instructions

Operating instructions	24
Attaching/detaching a Whizard Versa™ head to a Whizard Versa™ handle	24
Attaching Whizard Versa™ to power supply	24
Whizard Versa™ speed control	24
Operating the Whizard Versa™	25
Accessories	25

The manufacturer assumes no liability for any unauthorized changes in operating procedures or for unauthorized changes or modifications made to the design of the machine or any factory-installed safety equipment, whether these changes are made by the owner of this equipment, by his employees, or by service providers not previously approved by Bettcher Industries, Inc.



Use only replacement parts manufactured by Bettcher Industries, Inc. Use of substitute parts will void the warranty and may cause injury to operators and damage to equipment.

The use of parts other than those listed in the parts list for the specific model may cause blade lock-up, resulting in an unsafe operating condition.

OPERATING INSTRUCTIONS

Numbers refer to the item numbers on the device schematic on Page 2.

ATTACHING/DETACHING A WHIZARD VERSA™ HEAD TO A WHIZARD VERSA™ HANDLE

The Whizard Versa™ frame (#7) can be attached to the motor assembly (#5) in two positions 180° apart, one orientation has the lever (#4) in your palm and the other has it in your fingers.

- Align the black dot on the frame (#7) to the open circle on the motor assembly (#5) and slide the frame down.
- Turn until the dots align on the frame and motor assembly, this should lock into place and a snapping sound can be heard.
- To remove the frame from the motor assembly, turn the frame a quarter turn to the left and lift it off of the cone.

ATTACHING WHIZARD VERSA™ TO POWER SUPPLY

Connect the Whizard Versa™ tool power cord to the universal power supply brick prior to plugging the power supply in. Failure to follow these instructions may cause a spark or popping sound.



The Whizard Versa™ power supplies use a locking connection. It takes two and a half turns to secure the connection.

WHIZARD VERSA™ SPEED CONTROL

The Whizard Versa™ has two motor speeds controlled by the speed button (#2). On high speed, a red LED will light up; the LED will be off in low speed mode.

OPERATING THE WHIZARD VERSA™

- The safety latch (#3) must be held down to actuate the tool. To stop the tool, let go of the lever (#4).
- Always hold the Whizard Versa™ with your thumb extended. Let the handpiece rest naturally in the palm of the hand in a relaxed manner. Each person should hold the handpiece in a position that is most comfortable to them.
- The most-used motion is a long sweeping or gliding stroke across the trimming surface. Hold the blade surface as flat to the trim surface as possible. A scooping action, such as dipping ice cream, should be used around the vertebra.
- On flat bones, such as backbones or blades, use a long, quick gliding stroke.
- During the cutting operation **DO NOT** try to pull the blade out of a cut. Let the blade do the work as you would any other cutting tool.
- Grease tool as needed during operation and after cleaning, using the grease fitting (#8).

ACCESSORIES

DEPTH GAUGES

Some models (X880 + (B and S), X1880+, X1400+ and X1500+) come equipped with an adjustable depth gauge for setting a controlled product trim thickness. The depth gauge can be adjusted for cuts up to 1/4" thick. A depth gauge setting device is also available.

- Slide the depth gauge (#10) downward along the cover assembly (#13) grooves until the depth gauge clamps catch in position.
- The final height adjustment can be made after the blade is installed.
- Tighten the two attachment screws (#14).

WHIZARD VERSA™ GYRO AND SHAWARMA DEPTH GAUGES

The Whizard Versa™ gyro and shawarma heads come with an adjustable depth gauge for setting a controlled product trim thickness. These gauges are set with a single knob. The knob can be loosened by hand to set the thickness then tightened to secure the gauge in place.

SECTION 4

Maintenance

Disassembly of handpiece	28
Assembly of handpiece	29
Daily inspections and maintenance	30
Cleaning	31
Blade sharpening	32
Steeling the blade	33
Troubleshooting	34

To avoid personal injury, always disconnect the power cord before performing any adjustments, disassembly/assembly, troubleshooting or cleaning.

Always disconnect the power and remove the tool from the power supply prior to servicing.



DISASSEMBLY OF HANDPIECE

Sharp blades may cause cut injury!

For proper protection of hands, a protective glove should be used when operating this equipment and during the handling of blades. Metal mesh gloves are recommended for the free hand.

Keep hands away from moving blade.



Numbers refer to the item numbers on the device schematic on Page 2.

- First, remove the frame (#7) from the motor assembly (#5). Turn the frame (#7) a quarter turn to the left and lift it off of the cone.
- To remove the blade, hold the tool in your hand with the blade edge facing upward.
- Loosen the two blade housing mounting screws (#19) about 1/2 turn.
- Using a nut driver/screw driver turn the cam (#17) clockwise about 1/8 of a turn until it locks the housing (#15) in the open position.
- Remove the blade (#16) from the blade housing (#15).
- Loosen both blade housing mounting screws (#19) until the cam plate assembly (#18) and cam (#17) are free.

NOTE: The screws will stay in the cam plate assembly.

- Remove the blade housing (#15).
- If using the optional depth gauge (#10), it must be removed before the cover (#13). Loosen the two attachment screws located inside the depth gauge and slide the gauge upwards until it is out of the housing plates' (#15) grooves.
- Loosen both cover screws (#14) until the cover (#13) is free. For small heads the cover screws (#14) do not need to be fully removed; for large heads the cover screws (#14) are retained in the cover (#13).
- Pull the pinion (#12) out of the frame.
- The bearing (#11) is pulled out from the front of the tool. **DON'T** use a screwdriver to remove the bearing as that could damage it. If the bearing does not fall out on its own, use a bearing removal tool. **NOTE:** The bearing in the small tools do not have grease grooves.
- To remove the driver tip (#6), hold the motor assembly (#5) by the flats and turn the driver tip CLOCKWISE until it is free from the motor shaft. (Removing the driver tip is not standard maintenance for the tool).

NOTICE: The driver tip is a left-handed thread.

DO NOT over-tighten the driver tip. Doing so could break/fracture the driver tip.

ASSEMBLY OF HANDPIECE

Sharp blades may cause cut injury!

For proper protection of hands, a protective glove should be used when operating this equipment and during the handling of blades. Metal mesh gloves are recommended for the free hand.



Numbers refer to the item numbers on the device schematic on Page 2.

- First, slide the bearing (#11) into the frame (#7) bore and align the bearing slot with the frame pin. The bearing should go in with minimal effort and not require pressing.
- The pinion (#12) should now slide freely into the bearing (#11).
- Place the cover assembly (#13) on the frame (#7) and tighten the cover assembly screws (#14). Screws should be torqued to 25 in-lbs.
- Open housing by turning cam (#17) 1/8 turn clockwise and place the blade (#16) into the housing (#15).
- Place the cam (#17) onto the blade housing (#15), inserting the cam pins (#19) into each of the two slots located in the blade housing.

NOTE: For small tools, make certain the tab on the cam (#17) is pointing diagonal towards the cover. This will allow proper alignment of the cam tab with the slot in the cam plate assembly (#18).

- Screw the blade housing mounting screws (#17) into frame (#7) but leave them about 1/2 turn loose from tight.
- Install blade (#16) within the housing (#15). The blade should rotate freely.
- To attach the optional adjustable depth gauge (#10), slide the depth gauge downward along the housing (#15) plate grooves until the depth gauge clamps catch in position. Tighten the two attachment screws.
- The Whizard Versa™ frame (#7) can be attached to the motor assembly (#5) in two positions 180° apart, one orientation has the lever (#4) in your palm and the other has it in your fingers.

DAILY INSPECTIONS AND MAINTENANCE

Inspection of all parts for excessive wear is critical to ensure proper and safe operation. Vibration or lock-up may occur as a result of the use of excessively worn parts.

Sharp blades may cause cut injury!

Always disconnect power and remove the tool from the power supply prior to servicing.

After sharpening blade, all abrasive dust must be completely removed from the handpiece. Disassemble the unit and carefully wash each piece with hot, soapy water and a small brush.

Prior to assembly, be sure all parts are clean and have been inspected for wear.



Numbers refer to the item numbers on the device schematic on Page 2.

- Check for damage to the cutting edge of the blade (#16) and replace blade with performance degradation.
- Then, inspect the inner diameter of the housing (#15) for wear. Look for signs of corrosion or wear on the housing (#15), paying special attention to the area covering the gear teeth. If the edge of the housing (#15) is worn, exposing the pinion (#12) and blade teeth (#16), the housing (#15) should be replaced.
- With a new blade (#16) installed in the housing (#15), carefully check for movement of the blade in the housing from side to side and up and down.

NOTICE: If there is excess movement in the blade (#16) from side-to-side and/or up and down, the housing (#14) is **NOT** acceptable and needs replaced.

- Check for worn or chipped teeth on the pinion gear (#12). Worn out teeth are indicated by rounded off and pointed tops on the teeth.
- When installing a new pinion (#12), move the pinion side to side; if the bearing (#11) feels egg-shaped, it should be replaced. Expect the bearing (#11) to be replaced every 500 hours or use or sooner.
- Inspect the frame (#7) surfaces where the cover assembly (#13) mounts. Look for corrosion and any nicks or burrs that may prevent proper housing (#13) seating.
- Inspect the housing locating key (#15) for damage (Large tools only).
- Inspect the surface condition of the carbide steel (#13). If chipped or cracked it should be replaced.
- Make sure the steeling device (#13) and the plunger are free to move. The plunger and steel should be cleaned and oiled with mineral oil in order to keep free movement and prevent build-up of dirt.
- If using a depth gauge (#10), inspect it for wear or damage. Make certain the depth gauge clamps are not bent.

DAILY INSPECTIONS AND MAINTENANCE (CONTINUED)

- Check the cable (#1) for any nicks or cuts. If damaged, the parts should be replaced to avoid electrical shocks.
- Check to make sure that the lever (#4) is not bent such that would prevent the tool from turning on.
- Check to make sure the safety latch (#3) isn't broken.
- Check to make sure that the flutes on the driver tip (#6) are not broken/worn. If damaged/worn replace.
- Check to make sure the speed button (#2) cycles through low and high speed and doesn't get stuck.
- Check to make sure that frame (#7) isn't damaged/cracked.
- Check to make sure both ball bearings are present in the frame.

CLEANING

The recommended cleaning solution for the Whizard Versa™ is eXtra® Heavy Duty Cleaner. eXtra® Heavy Duty Cleaner, (PN: 184332), is a concentrated cleaner and degreaser for food processing equipment. Contact Bettcher Industries, Inc. for details.



CLEANING PRIOR TO ASSEMBLY

Prior to assembly, be sure all parts are clean and have been inspected for wear.

PERIODIC CLEANING DURING USE

Remove meat particles and rinse with warm soapy water. Wash the Whizard Versa™ with warm cleaning solution. For best results, clean the Whizard Versa™ with eXtra® Heavy Duty Cleaner, diluted according to the directions on the container. Rinse thoroughly with water.

CLEANING AFTER DAILY USE

- Disassemble and clean thoroughly daily.
- Remove the blade, blade housing, cam plate with cover, gauge, pinion cover, and bearing from the head frame. Clean all components with a brush or cloth, and cleaner. For best results, clean the Whizard Versa™ with eXtra® Heavy Duty Cleaner, diluted according to the directions on the container. Rinse thoroughly with water and dry.
- Clean the handle with warm, soapy water. **DO NOT SUBMERGE HANDLE.**
- Before assembly, rinse well with clean water and dry. Reassemble the components of the tool.
- Apply grease after cleaning to maintain tool.

BLADE SHARPENING

Sharp blades may cause cut injury!

For proper protection of hands, a protective glove should be used when operating this equipment and during the handling of blades.

After sharpening, all abrasive dust must be completely removed from the handpiece. Disassemble the unit and carefully wash each piece with hot, soapy water and a small brush.



- Sharpener should be placed at the edge of a work surface, using your non-sharpening hand to stabilize the sharpener. Knife sharpening oil may also be used.

WARNING! Never place your hand or any other part of your body near the spinning blades.



- Soak the sharpening stone for 10-15 minutes prior to sharpening. If necessary, rewet the stone during the sharpening/refining blade process. Sharpening oil may also be used.
- Ensure the blade is clean prior to sharpening.

- **FOR STRAIGHT BLADES (X350+, X620+ and X750+ - Diagram 1):** Using the coarse side (dark) of the sharpening stone: with head attached to tool, place housing back down on the plastic, slide the head against the stone and hold for 2-3 seconds while the blade is spinning.

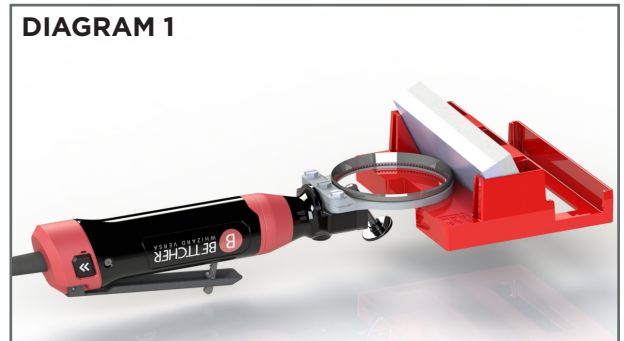

- **FOR HOOKED/ANGLED BLADES (X850+, X1850+, X1000+ and X1300+ - Diagram 2):** Using the coarse side (dark) of the sharpening stone: with head attached to tool, place the blade face down on the sanding stone and hold for 2-3 seconds while the blade is spinning. Be sure to keep the blade as flat as possible.

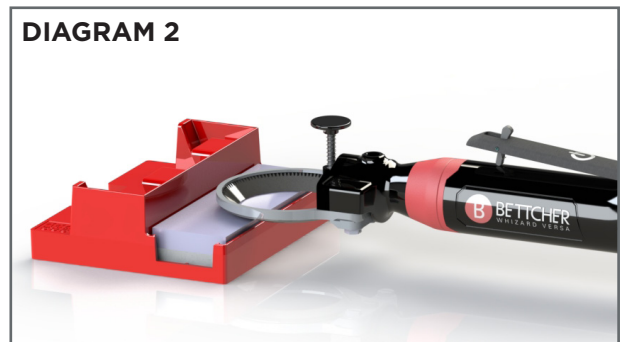

- Repeat as necessary to remove major nicks/dings in the blade.
- Using the fine side (light) of the sharpening stone, repeat above steps as necessary for desired sharpness.
- Use the attached steeling device and/or separate steeling rod to refine the edge.
- Clean blade of any sharpening stone residue prior to use.

STEELING THE BLADE

STEELING FOR MODELS: X360+, X505+, X850+, X880+, X1850+, X1880+, X1000+, X1300+, X1400+ AND X1500+

Use the Whizard Special Steel against the flat ground surface on the outside surface of the blade. Be sure to hold the "steel" flat and across the centerline of the blade to prevent "rounding off" or rolling of the edge.

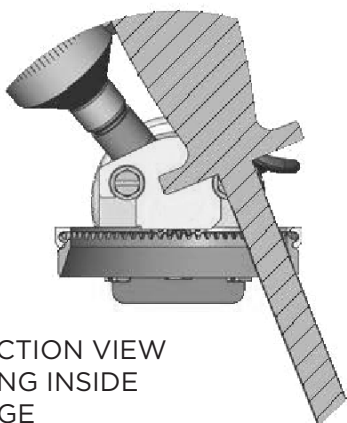

CROSS-SECTION VIEW
OF STEELING INSIDE
BLADE EDGE

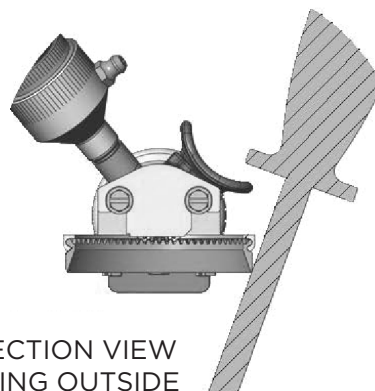

CROSS-SECTION VIEW
OF STEELING OUTSIDE
BLADE EDGE

The INSIDE edge of the blade should be steeled only with the Special Steeling Device mounted on the inside diameter of the blade housing. This is accomplished as follows:

- Hold the Whizard Special Steel on the bottom edge of the blade and the handpiece in your normal operating hand with the blade down, or away from you.
- With your thumb, lightly push down on the push button of the steeling device. **DO NOT** hold the steeling device against the rotating blade steadily, but rather lightly contact the blade edge.

Replace or sharpen the blade if this procedure does not improve the cutting action.

STEELING FOR MODELS: X350+, X440+, X500+, X500A+, X564+, X620+, X620A+ AND X750+

Be sure to hold the steel at the actual angle of the blade edge. Running the steel at an angle greater than the factory ground angle will round over the edge and make resharping more difficult.

Use the steel lightly and always make the last pass of the steel on the blade on the inside surface of the blade.

TROUBLESHOOTING

Problem	Probable Cause	Remedy
Motor unit will not run	Unsure	Depress and press the on/off lever to reset the tool electronics
	No power to unit	Confirm the connection to the universal AC power supply or battery pack is securely fastened. Check the universal AC power supply to ensure it is plugged in a the blue LED indicates the power supply is on
	Defective/damaged motor	Replace
	Tool is over heated	Let tool cool down
Motor runs, but blade doesn't spin	Pinion is worn or damaged	Replace
	Driver tip is worn or damaged	Replace
Tool runs hot	Fat/grease build up	Clean the tool thoroughly, <i>refer to Section 4</i>
	Prolonged tool use	Let the tool cool down
Tool vibrates excessively	Grease/fat buildup in blade, housing, or pinion	Clean the tool thoroughly, <i>refer to Section 4</i>
	Lack of grease	Grease the tool
	Worn pinion	Replace
	Worn blade	Replace
	Worn housing	Replace
Tool does not cut properly	Dull blade	Sharpen and re-steel blade
	Depth gauge improperly adjusted	Re-adjust depth gauge

SECTION 5

Service Parts

Whizard Versa™ - part numbers

36

Also available

39

The manufacturer assumes no liability for any unauthorized changes in operating procedures or for unauthorized changes or modifications made to the design of the machine or any factory-installed safety equipment, whether these changes are made by the owner of this equipment, by his employees, or by service providers not previously approved by Bettcher Industries, Inc.



Use only replacement parts manufactured by Bettcher Industries, Inc. Use of substitute parts will void the warranty and may cause injury to operators and damage to equipment.

The use of parts other than those listed in the parts list for the specific model may cause tooth roll lock-up, resulting in an unsafe operating condition.

WHIZARD VERSA™ - PART NUMBERS

Item numbers correspond to the device schematic on Page 2.

HEAD ASSEMBLIES

Item	Description	PART No.
7	X350+ Head Assembly, Whizard Versa™	130350
7	X620+ Head Assembly, Whizard Versa™	130620
7	X750+ Head Assembly, Whizard Versa™	130750
7	X850+ Head Assembly, Whizard Versa™	130850
7	X1850+ Head Assembly, Whizard Versa™	130185
7	X1000+ Head Assembly, Whizard Versa™	130100
7	X1300+ Head Assembly, Whizard Versa™	130130
7	Gyro Head Assembly, SS, Whizard Versa™ (NSF)	130885
7	Gyro Head Assembly, CS, Whizard Versa™	130887
7	Shawarma Head Assembly, SS, Whizard Versa™ (NSF)	130188
7	Shawarma Head Assembly, CS, Whizard Versa™	130187

MOTOR ASSEMBLIES/ POWER SUPPLIES

Item	Description	PART No.
1, 2, 3, 4, 5	Motor Assembly, Whizard Versa™	130000
	Motor with Power Supply, Whizard Versa™, US	130003
	Motor with Power Supply, Whizard Versa™, EU	130005
	Motor with Power Supply, Whizard Versa™, BR	130006
	Motor with Power Supply, Whizard Versa™, UK	130007
	Power supply, US	130210
	Power supply, EU	130215
	Power supply, BR	130211
	Power supply, UK	130012

WHIZARD VERSA™ - PART NUMBERS (CONTINUED)

Item numbers correspond to the device schematic on Page 2.

BLADES

Item	Description	PART No.
16	X350+ Blade	107188
16	X620+ Blade	107185
16	X750+ Blade	105042
16	X850+ Blade	104834
16	X1850+ Blade, CS	105497
16	X1850+ Blade, Serrated, CS	107053
16	X1850+ Blade, SS (NSF)	121703
16	X1850+ Blade, Serrated, SS (NSF)	121704
16	X1000+ Blade	104881
16	X1300+ Blade	104882
16	X1300+ Blade, Serrated	105542

REBUILD KIT

Item	Description	PART No.
9, 13, 14, 15, 17, 18, 19	X350+ Rebuild Kit - Cam, Cam Plate Assembly, Blade Housing, Cover Assembly	130984
9, 13, 14, 15, 17, 18, 19	X620+ Rebuild Kit - Cam, Cam Plate Assembly, Blade Housing, Cover Assembly	130985
9, 13, 14, 15, 17, 18, 19	X750+ Rebuild Kit - Cam, Cam Plate Assembly, Blade Housing, Cover Assembly	130986
9, 13, 14, 15, 17, 18, 19	X850+ Rebuild Kit - Cam, Cam Plate Assembly, Blade Housing, Cover Assembly	130987
9, 13, 14, 15, 17, 18, 19	X1850+ Rebuild Kit - Cam, Cam Plate Assembly, Blade Housing, Cover Assembly	130990
9, 13, 14, 15, 17, 18, 19	Gyro/Shawarma SS Rebuild Kit - Cam, Cam Plate Assembly, Blade Housing, Cover Assembly (NSF)	130991
9, 13, 14, 15, 17, 18, 19	X1000+ Rebuild Kit - Cam, Cam Plate Assembly, Blade Housing, Cover Assembly	130988
9, 13, 14, 15, 17, 18, 19	X1300+ Rebuild Kit - Cam, Cam Plate Assembly, Blade Housing, Cover Assembly	130989

WHIZARD VERSA™ - PART NUMBERS (CONTINUED)

Item numbers correspond to the device schematic on Page 2.

GAUGES

Item	Description	PART No.
10	Gyro Depth Gauge (NSF)	130110
10	Shawarma Depth Gauge (NSF)	130115
10	(X850+) Depth Gauge Assembly add to make X880+S	183076
10	(X850+) Depth Gauge Assembly add to make X880+B	183075
10	(X1850+) Depth Gauge Assembly add to make X1880+	183077
10	(X1000+) Depth Gauge Assembly add to make X1500+	183160
10	(X1300+) Depth Gauge Assembly add to make X1400+	183159

OTHER SPARE PARTS

Item	Description	PART No.
11, 12	Pinion/Bearing Kit, Small	130982
11, 12	Pinon/Bearing Kit, Large	130983
7	Frame, Small	130251
7	Frame, Large	130252
6	Driver Tip, Q Flex, Small Pinion	104275
20	Bolt Cover (NSF)	130993

ALSO AVAILABLE

CLEANING

Description	PART No.
eXtra© Heavy Duty Cleaner (1 Gallon)	184332
Handpiece Cleaning Kit (Contains the following)	184334
Handpiece Cleaning Pick	184335
Stainless Steel Hand Brush	184336
Scrub Brush	184337
1-1/2" Diameter Tubing Brush	184338
1/2" Diameter Tubing Brush	184339

LUBRICATION

Description	PART No.
13.5 oz. Cartridge of Whizard Quantum® High Performance Grease	102609
Whiz-Lube Spray	173519
Quantum Grease Squeeze Tube, 8 oz	104098
Planetary Gear Grease Gun	113326
Grease Fitting	102273

TOOLS/ SHARPENING

Description	PART No.
Bearing Removal Tool (Small Tool)	107330
Bearing Removal Tool (Large Tool)	184983
Hex Tool	130955
Whizard Versa™ Sharpener Assmely with Stone	130950
Whizard Versa™ Sharpener, Stone	130953

SECTION 6

Contact and Document Information

Contact address and phone

42

Document identification

43

CONTACT ADDRESS AND PHONE

For additional information, technical support and spare parts, contact your Regional Manager, Distributor, or Bettcher Representative:

Bettcher Industries, Inc.

P.O. Box 336

Vermilion, Ohio, 44089

USA

Tel: +1 440/965-4422

Fax: +1 440/328-4535

BETTCHER GmbH

Pilatusstrasse 4

CH-6036 Dierikon

Switzerland

Tel: +011-41-41-348-0220

Fax: +011-41-41-348-0229

Bettcher do Brasil Comércio de Máquinas Ltda.

Av. Fagundes Filho, 145 Cj 101/102 - São Judas

São Paulo - SP

CEP 04304-010 - BRASIL

Tel: +55 11 4083 2516

Fax: +55 11 4083 2515

DOCUMENT IDENTIFICATION

Copies of this Operation Instruction may be ordered by quoting the Document ID as listed below:

Document ID: Manual #130555

Document Description: Operating Instructions and Spare Parts List for the Whizard Versa™

Issued: Date: August 1, 2024

Operating Instructions for the Whizard Versa™ may be requested by quoting the model designation of the tool.

SOFTWARE AND DUPLICATION

For more information, contact your local Representative or:

Bettcher Industries, Inc.

Administrative Assistant/Engineering Department PO Box 336

Vermilion, Ohio 44089, USA



MANUAL #130555, ISSUED: AUGUST 1, 2024